

CLARKE®



AIR COMPRESSOR XE RANGE - ELECTRIC MOTOR DRIVEN

OPERATION & MAINTENANCE INSTRUCTIONS



ORIGINAL INSTRUCTIONS

DL0822 - ISS 6

INTRODUCTION

Thank you for purchasing this CLARKE compressor which is designed to supply compressed air to air powered tools for a wide range of applications such as spraying, sanding, drilling, and cutting.

Before attempting to use this product, please read this manual thoroughly and follow the instructions carefully. In doing so you will ensure the safe operation of the compressor.

Please Note, these compressors are for indoor use only.

GUARANTEE

This product is guaranteed against faulty manufacture for a period of 12 months from the date of purchase. Please keep your receipt which will be required as proof of purchase.

This guarantee is invalid if the product is found to have been abused or tampered with in any way, or not used for the purpose for which it was intended.

Faulty goods should be returned to their place of purchase, no product can be returned to us without prior permission.

This guarantee does not effect your statutory rights.

ENVIRONMENTAL RECYCLING POLICY



Through purchase of this product, the customer is taking on the obligation to deal with the WEEE in accordance with the WEEE regulations in relation to the treatment, recycling & recovery and environmentally sound disposal of the WEEE.

In effect, this means that this product must not be disposed of with general household waste. It must be disposed of according to the laws governing Waste Electrical and Electronic Equipment (WEEE) at a recognised disposal facility.

SPARE PARTS AND DIAGRAMS

Spare parts and diagrams are available on request by contacting our parts and service department on 020 8988 7400.

MODELS COVERED AND NOISE DATA

Model Number	Sound Power level dB(LWA)	Sound Pressure level dB(LAeq)
XEV11/100	98	81
XEPV11/50	98	75
XEPVH11/50	98	75
XEP15/50	101	78
XEPV16/50	99	77
XEPVH16/50	99	77
XE15/150	98	81
XEV16/100	98	82
XEV16/150	101	84
XEV16/200	101	84
XEV26/200	99	81
XE18/200	104	87
XET19/200	100	83
XE25/200	102	84
XE29/270	105	87
XE36/C200	110	92.3
XE37/270	106	88

RESIDUAL RISK

Although this manual contains extensive safety warnings and information on the safe operation of your compressor, every tool does have certain residual risks which cannot be completely excluded with warnings or safety devices. This compressor must therefore always be operated with caution.

SAFETY PRECAUTIONS

Before using your compressor it is in your own interest to read and pay attention to the following safety rules:

1. **COMPRESSED AIR IS DANGEROUS** - Never direct a jet of air at people or animals.
2. Do not operate your air compressor with any guards removed.
3. Electrical or mechanical repairs should only be carried out by a qualified electrician/engineer. If you have a problem, contact your local dealer, or our Service Department on 020 8988 7400
4. Before attempting any repair ensure pressure is expelled from the air receiver and disconnect from electrical supply.
5. Do not leave pressure in air receiver overnight or when transporting.
6. Do not adjust or tamper with any safety valves. The maximum working pressure of the compressor is clearly stated on the machine.
7. Exercise caution when transporting the machine to avoid tipping the machine over.
8. Do not operate in a wet/damp environment.
9. Locate your air compressor on a firm flat surface with AVMs and ensure an adequate supply of clean air is available to the pump unit.
10. Do not exert any strain on electrical cables and ensure that air hoses are not tangled or wrapped around machinery etc.
11. The cylinder head and delivery pipes of your compressor become quite hot during operation. Do not touch. After switching off remember to leave an adequate cool-down period before touching.
12. Ensure that any equipment/tool used in conjunction with your compressor has a safe working pressure exceeding the output pressure of the machine.
13. When disconnecting air hoses or other equipment from your compressor ensure that the air supply is turned off at the machine outlet and expel all pressurised air from within the air hose and other equipment attached to it.
14. If using your compressor for paint spraying:
 - Never spray close to any source of flame or heat.
 - Always ensure that the spraying area has adequate fresh air ventilation.
 - Hazardous paints require special apparatus (see paint manufacturers recommendations).
15. Never let people operate the compressor unless they have had the necessary training.
16. Permanently installed pipework systems should be designed and installed by a competent engineer.

INSTALLATION

Before installing your machine, check that its air output is sufficient for the equipment to be used. The air output from the compressor must be more than the volume of air required. We recommend the following:

1. **Firm and level site, and the use of floor mountings for stationary compressors - anti-vibration pads. (Do not bolt machines directly to the floor).**



WARNING: MOVE THE COMPRESSOR ON A PALLET OR USING SLINGS BENEATH THE RECEIVER NEAR TO THE DOMED ENDS, EMPLOYING A FORK LIFT TRUCK OR WHEELED GANTRY CRANE. BEWARE OF OFF CENTRE LOADS. THE WEIGHT OF THE COMPRESSOR IS SHOWN ON THE DATA TABLE ON PAGE 2.

2. Dust and damp free environment.
3. Adequate ventilation for:-
 - Air intake to compressor pump (in order to draw in clean air).
 - Cooling to compressor pump, and electric motor.
4. To allow sufficient access for servicing, a minimum clearance of 500mm must be allowed around the machine.
5. The power cable from the main supply must be large enough to carry the starting and running load of the electric motor. This is particularly relevant if the compressor is some distance from the source of supply.
6. Electrical installations should be completed by a qualified electrician.
7. Electrical connection to the mains supply must be via a suitably fused (see table on page 6) approved plug or isolator (allowing sufficient capacity for motor starting). If using a circuit breaker, ensure it is motor rated and of sufficient size to allow for motor starting.
8. Compressors should be connected to mains electricity supply via an earth leakage protection device (RCD).

ELECTRICAL CONNECTIONS

See wiring lable on the power cable.

SUGGESTED FUSE RATINGS

MOTOR SIZE		SINGLE PHASE MOTOR D.O.L.	THREE PHASE MOTORS 415V	
KW	HP		DOL	STAR DELTA
0.75	1.0	13 amp	10 amp	
1.1	1.5	13/15 amp	10 amp	
1.5	2.0	20 amp	10 amp	
1.9	2.5	20 amp		
2.2	3.0	30 amp	16 amp	
3.0	4.0	40 amp	20 amp	
4.0	5.5		25 amp	
5.5	7.5		30 amp	
7.5	10.0			25 amp

LUBRICATION

Pump: Use Clarke compressor oil, as indicated on machine plate.

BEFORE STARTING COMPRESSOR, CHECK:-

1. Compressor Pump Oil Level using (a) Dipstick (to level marked) or (b) sight glass (see fig.1)
2. Automatic Control:- Pressure switch ON/OFF switch is in the OFF position.

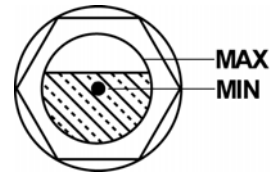

WARNING:



1. BEFORE STARTING COMPRESSOR, OPEN ALL OUTLET VALVES.
 2. THE FOLLOWING START AND STOP INSTRUCTIONS MUST BE FOLLOWED IN THE CORRECT SEQUENCE TO AVOID SERIOUS DAMAGE TO THE COMPRESSOR/MOTOR.
-

TO START COMPRESSOR

1. Switch on isolator (mains supply)
2. Switch on pressure switch (lift knob or twist switch). (See "GENERAL ARRANGEMENT" on page 8., item 22)
3. Check rotation (Flywheel/Fan blows air over pump)
4. Check that pressure does not exceed maximum working pressure (stamped on machine plate), if the pressure exceeds the maximum working pressure stated, stop the machine (see below), vent the system and contact the Clarke Service Department.

TO STOP COMPRESSOR

1. Switch off at the pressure switch (Push knob down or turn switch).
 2. Isolate from the Mains Supply.
 3. Drain air receiver (release drain tap).
-



WARNING: COMPRESSOR PUMPS, DELIVERY PIPES WILL REMAIN HOT FOR SOME TIME AFTER USE.

NOTE: When starting compressors up to and including the 3HP models, an auto bleed valve will operate and air will be heard vent. This is quite normal and should not cause concern. The valve should close after several seconds. Should it fail to close, consult your Clarke dealer.

GENERAL ARRANGEMENT

A. STATIONARY

NB: Must be mounted on Anti Vibration Pads

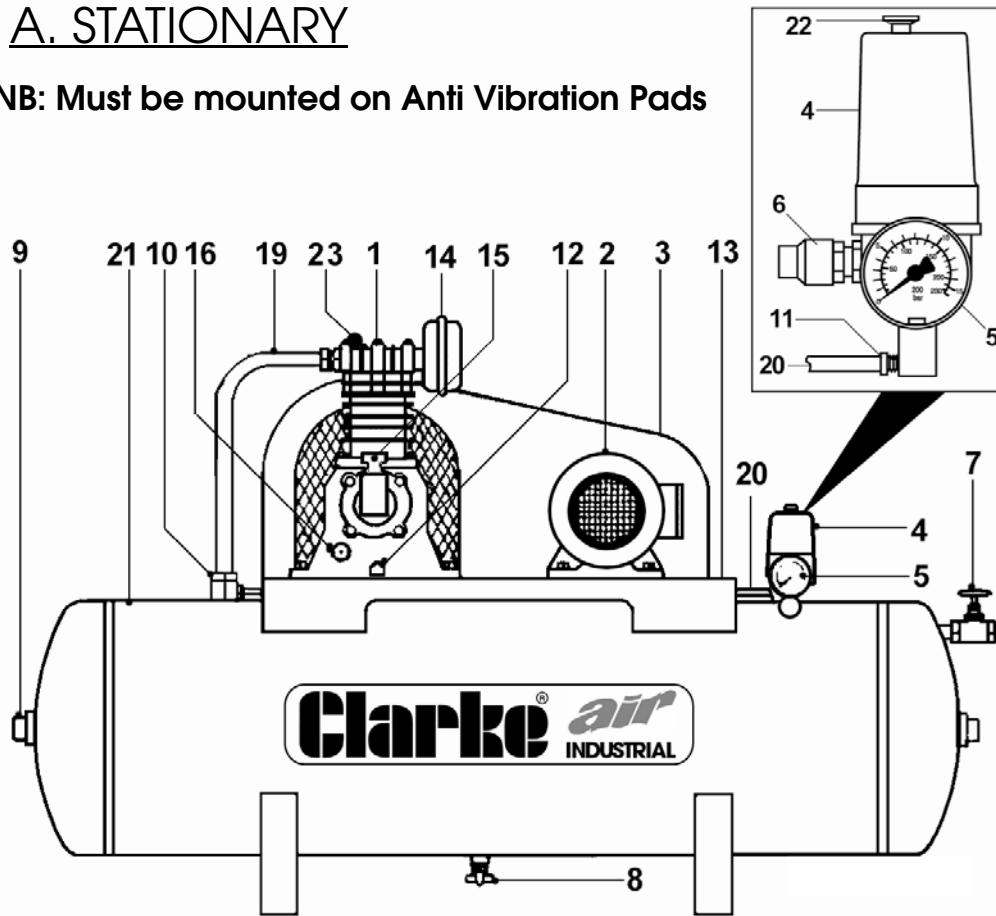

Fig.2

Illustrative purposes only

1	Air Compressor Pump	9	Inspection Plug	17	-
2	Electric Motor (or	10	Non-Return Valve	18	-
3	Wire Guard	11	Air Bleed Valve	19	Air Delivery Pipe
4	Pressure Switch	12	Oil Drain Plug	20	Air Bleed Pipe
5	Pressure Gauge	13	Saddle	21	Air Receiver
6	Safety Valve	14	Air Intake Filter	22	On/Off switch
7	Ball Valve	15	Oil Filler/Breather	23	Auto Air Bleed
8	Drain Tap	16	Oil Level Sight Glass		

NOTE: On automatic machines (10 H.P). a solenoid valve is fitted to the delivery pipe.

NOTE: On automatic machines (10 H.P), an Auto Star Delta (ASD) starter is fitted, ready to be mounted to a wall or panel etc. It is **IMPORTANT** to note that **NO ADJUSTMENTS** should be made to this component. The ASD should be connected to a 3-phase supply by a qualified electrician.

OUTLET PRESSURE ADJUSTMENTS

PORTABLE COMPRESSORS

1. Pressure Adjusting Knob
2. Outlet Taps
3. Pressure Gauge

TO ADJUST OUTLET PRESSURE:

To increase pressure - turn knob (1) clockwise. To decrease pressure - turn knob (1) anticlockwise.
Outlet taps - slide knurled section (2) away from body to open, push towards body to close.

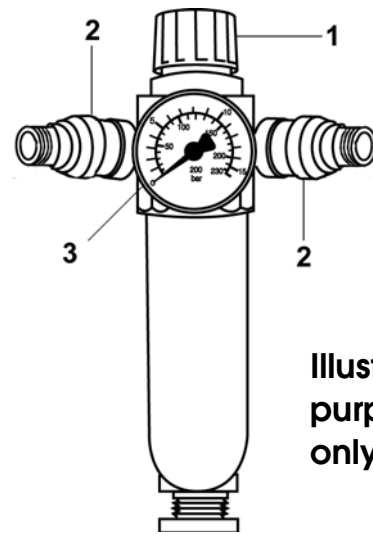

Illustrative purposes only

NOTE: Pressure Gauge (3). Pressure shown will differ by approximately 1 bar depending on whether the outlets are open/closed.

STATIONARY COMPRESSORS

These machines are not supplied with the facility to adjust outlet pressure. A comprehensive range of airline accessories is available from your local CLARKE stockist.

OVERLOAD BUTTON (SINGLE PHASE ONLY)

The electric motor is fitted with an automatic overload detector which will stop the motor if an overload is detected.

If this happens,

1. **SWITCH OFF THE PRESSURE SWITCH** (Push knob down or turn switch).
 - Allow the compressor to cool down for 5-10 minutes.
2. Press the Reset button shown on the right.
3. Switch on pressure switch (lift knob or twist switch).

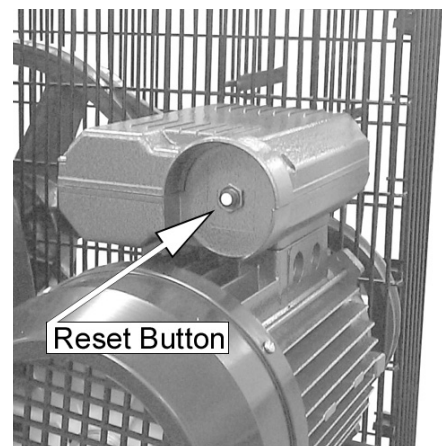

If the overload trips repeatedly, it may indicate a fault with the compressor, in this case you should contact the Clarke service department.

OTHER PRODUCTS WITHIN OUR RANGE In addition to Air Compressors from 3-40 cfm, we offer a vast range of air tools and airline equipment. Please ask your local dealer for details of our range or a copy of our Power Products Catalogue

TROUBLESHOOTING CHART

IMPORTANT!

1. Any remedial work that may be required must be carried out by a qualified electrician/engineer.
2. Disconnect from the mains supply before removing any parts from the compressor.
3. Empty Air Receiver of Air before dismantling any part of the compressor unit's pressure system.
4. If your compressor develops a fault do not use until the fault has been rectified.

SYMPTOM	PROBABLE CAUSE	REMEDY	
Compressor will not start automatically	Fault in electrical installation	Let an electrician check electrical installation.	
	Current supply failure.		
	Voltage drop.		
	Motor starter faulty.		
	Motor incorrectly connected or faulty	Reset by depressing button.	
	Starter overload has tripped out.		
	Pressure switch defective.		Have pressure switch changed by an electrician.
	Fuse blown.		Check fuse rating - replace.
Compressor unit will not stop automatically.	Pressure switch defective.	Contact Clarke Service	
Fuses keep blowing.	Inadequate size fuse installed.	Replace with reference to chart See page 6.	
	Fault in motor.	Contact Clarke Service	
Bleed valve under pressure switch blows whilst compressor is not running	Non-return valve leaking.	Clean non-return valve or replace.	

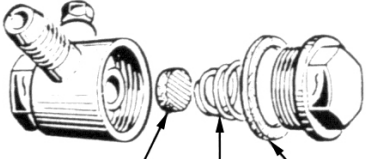
SYMPTOM	PROBABLE CAUSE	REMEDY
Bleed valve under pressure switch blows whilst compressor is running	Non return valve stuck (NRV) open at junction of the tank and the pump delivery pipe.	Drain Tank and remove inspection nut to clean Non Return valve  Valve Spring Gasket
Compressor unit starts, but stops again after only a few revolutions.	Non-return valve leaking (compressor unit is on load during start).	Disconnect from the mains supply and empty air receiver. Clean or replace
	Non-return valve blocked, possibly frozen up.	Thaw non-return valve out (Unit must be installed in frost-free place).
	Solenoid valve leaking or defective (only applies to 10 HP machines and above).	Contact Clarke Service
Unusual noise from compressor	Bolts loose.	Tighten Bolts.
	V-Belt flywheel or cooling coil touching belt guard	Find place of contact and remedy fault.
	Flywheel loose.	Tighten flywheel.
	Unit installed on an unsuitable base.	Move unit to a more solid base
	Bearings, piston rings or cylinder worn.	Contact Clarke Service
	Valve broken.	Contact Clarke Service
	Bearings of electric motor worn	Contact Clarke Service
Compressor unit starts and stops more frequently than usual.	Large amount of condensation in air receiver.	Drain off condensation AT LEAST once a week.
	Leaks in control unit or inspection cover.	Locate leaks (by means of soapy water) and repair.
	Too little pressure differential.	Contact Clarke Service

SYMPTOM	PROBABLE CAUSE	REMEDY
Compressor's oil consumption rising.	Too much oil in compressor.	Check oil level 2 or 3 minutes after stopping.
	Leaks around crank case.	Contact Clarke Service
	Working temperature of compressor too high because of insufficient cooling.	Increase ventilation to air compressor.
	Unit too small in proportion to air consumption.	Connect supplementary.
	Semi-automatic unit Load too small.	Convert to fully automatic operation.
	Cylinder worn	Contact Clarke Service
	Intake air filter blocked.	Clean / Change air filter.
Compressor runs continuously and can't attain the working pressure required.	Suction filter blocked.	Change filter.
	V-belt too slack (not applicable to direct drive machines).	Tighten V-Belt.
	Leak between compressor block and air receiver/ leaks in or near air receiver.	Tighten connection and repair leak or Contact Clarke Service
	RPM too low because of incorrectly connected electric motor.	Contact Clarke Service
	Valves blocked by dirt, paint, dust or coked up.	Contact Clarke Service
	Inspection cover or plug leaking	Empty air receiver and change seal or Contact Clarke Service
	Suction rendered difficult or impossible at suction intake or the air being taken in is too warm.	Ensure unobstructed air flow around the unit.
	Pressure gauge defective.	
	Unit too small in relation to air consumption of connected equipment	Install a larger compressor
	Compressor worn.	Have compressor overhauled or replace it.
Compressor unit starts when no air is being used.	Leaks in pipework system	Locate and repair leaks.

SYMPTOM	PROBABLE CAUSE	REMEDY
Machine running but not pumping air into the receiver (10HP only)	Air exhausting from solenoid after starter has changed direction from star to delta.	Check solenoid valve
		Contact Clarke Service
Compressor becomes too hot.	Insufficient ventilation	See that sufficient air is supplied to flywheel or fan of compressor and that hot air is properly vented.
	Oil level too low (check 2 or 3 times after stopping).	Fill with oil - See page 7.
	Fault in valves (machine not stopping).	Contact Clarke Service
	Blown head gasket (machine not stopping).	Contact Clarke Service
	Dirt on cooling fins or suction filter.	Clean cooling fins and suction filter.
	Unit working at too high a pressure	Contact Clarke Service
	Non-return valve partly blocked.	Clean or thaw out non-return valve.
	Compressor being overworked and running continuously.	Use a larger compressor
Oil in the air delivered	Sump over full	Reduce oil to correct level
	Cylinder worn	Contact Clarke Service
	Intake air filter blocked	Change air filter
Condensation in crank case (especially in 2-stage compressors).	Compressor over dimensioned (operational periods too short in relation to resting periods).	Frequent oil changes Reduce Cooling of crank case (e.g. by shielding it from the air stream). Contact Clarke Service
Condensation at outlet points	Piping installation is incorrect	Consult your local dealer
	Compressor is taking in air that is too warm	Obtain better fresh air supply for the compressor.
	Delivery temperature of air from air receiver is too high	Use a larger air receiver
		Contact Clarke Service

SYMPTOM	PROBABLE CAUSE	REMEDY
Electric motor too hot: Maximum temperature 90oC (194oF).	Operational voltage too low	Call an electrician
	Faults in electrical installation	Contact Clarke Service
	Cooling fins of electric motor blocked by dirt	Clean Cooling fins

MAINTENANCE CHART

CHECK LIST	DAILY	WEEKLY	6 MONTHLY	NOTES
Oil level	Check		Change	
Air Receiver	Drain			
Intake Filter		Check / Clean		Replace if necessary
Oil breather		Check / Clean		
Fan and cooling fins		Clean		
Inlet and outlet valves				If worn Contact Clarke Service department
Non Return Valve		Clean	Replace if worn	
Belt Tension			Check / Adjust / Replace if worn	Does not apply to direct drive
Big end bearings			Check	If worn Contact Clarke Service department
Main bearings			Check	If worn Contact Clarke Service department
Piston Rings				If worn Contact Clarke Service department
Cylinder head bolts		Check Torque settings		See above for details.

DECLARATION OF CONFORMITY



Clarke[®]
INTERNATIONAL

Hemnal Street, Epping, Essex CM16 4LG

DECLARATION OF CONFORMITY

This is an important document and should be retained.

We hereby declare that this product(s) complies with the following directive(s):

- 2004/108/EC *Electromagnetic Compatibility Directive.*
- 2006/42/EC *Machinery Directive.*
- 2011/65/EU *Restriction of Hazardous substances.*
- 2009/105/EC *Simple Pressure Vessel Directive.*
- 2000/14/EC *Noise Emissions Directive, (amended by 2005/88/EC).*

The following standards have been applied to the product(s):

- EN 1012-1:2010, EN 61000-6-1:2007, EN 61000-6-3:2007+A1:2011, EN 61000-3-2:2006+A2:2009,
- EN 61000-3-3:2008

The technical documentation required to demonstrate that the product(s) meet(s) the requirement(s) of the aforementioned directive(s) has been compiled and is available for inspection by the relevant enforcement authorities.

The CE mark was first applied in: 2016

Signed:



J.A. Clarke
Director

A SELECTION FROM THE VAST RANGE OF

Clarke®

QUALITY PRODUCTS



AIR COMPRESSORS

From DIY to industrial, Plus air tools, spray guns and accessories.

GENERATORS

Prime duty or emergency standby for business, home and leisure.

POWER WASHERS

Hot and cold, electric and engine driven - we have what you need

WELDERS

Mig, Arc, Tig and Spot. From DIY to auto/industrial.

METALWORKING

Drills, grinders and saws for DIY and professional use.

WOODWORKING

Saws, sanders, lathes, mortisers and dust extraction.

HYDRAULICS

Cranes, body repair kits, transmission jacks for all types of workshop use.

WATER PUMPS

Submersible, electric and engine driven for DIY, agriculture and industry.

POWERTOOLS

Angle grinders, cordless drill sets, saws and sanders.

STARTERS/CHARGERS

All sizes for car and commercial use.

PARTS & SERVICE: 0208 988 7400

Parts Enquiries
Parts@clarkeinternational.com

Servicing & Technical Enquiries
Service@clarkeinternational.com

SALES: UK 01992 565333 or Export 00 44 (0)1992 565335

Clarke INTERNATIONAL Hemnall Street, Epping, Essex CM16 4LG
www.clarkeinternational.com